

Welding Flange Stainless Steel 316LN

INFICON CF quality fittings are manufactured according to ISO 3669 and the latest TS/ ISO 3669-2 standard. INFICON Ultra high vacuum fittings are designed for applications down to 1×10^{-12} mbar and bakeout temperatures up to 400°C.



BENEFITS

- World wide logistics
- Design and measures follow strictly international respected standards
- Surface finish, welds, material specifications and cleanliness meet or exceed high vacuum specifications
- 2011/65/EU RoHS compliant

ORDER INFORMATION

Type	DN 16 CF	DN 40 CF	DN 63 CF	DN 100 CF	DN 160 CF	DN 200 CF
Welding flange DN 100 CF-F				213-124		
Welding flange DN 16 CF	213-121					
Welding flange DN 160 CF-F					213-125	
Welding flange DN 200 CF-F						213-126
Welding flange DN 250 CF-F						
Welding flange DN 63 CF-F			213-123			
Welding-Flange DN 40 CF-F		213-122				

DN 250 CF

213-127

SPECIFICATIONS

Type	DN 16 CF	DN 40 CF	DN 63 CF	DN 100 CF	DN 160 CF	DN 200 CF
Dimension A	7.5	13	17.5	20	22	24.5
Dimension B	3.3	7.5	8	9	10	12
Dimension C	17.2	39.5	66	104	155	205
Dimension D	18	40	70	108	159	205
Dimension E	1	1.5	2	2	2	2.5
Material:	Stainless Steel 316LN / 1.4429	Stainless Steel 316LN / 1.4429	Stainless Steel 316LN / 1.4429	Stainless Steel 316LN / 1.4429	Stainless Steel 316LN / 1.4429	Stainless Steel 316LN / 1.4429

DIMENSIONS

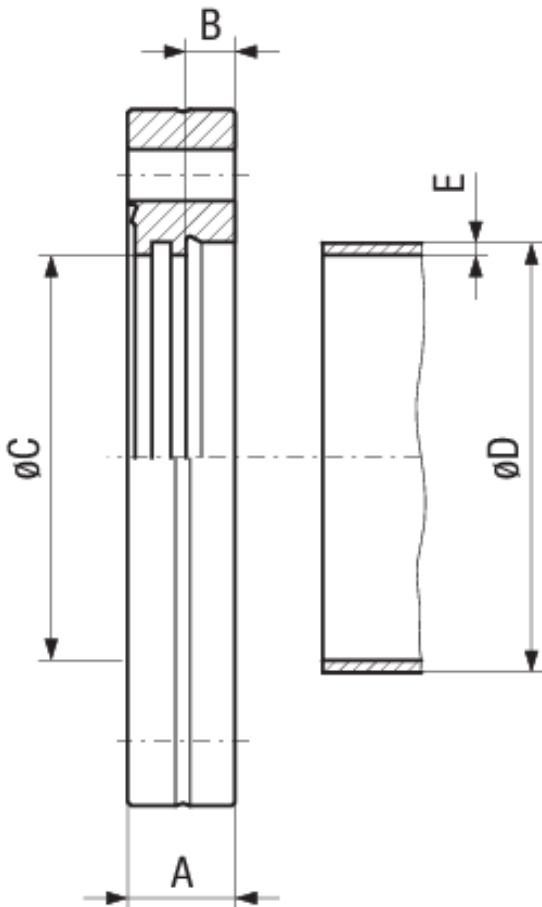

SPECIFICATIONS

Type	DN 250 CF
Dimension A	24.5
Dimension B	12
Dimension C	256
Dimension D	256
Dimension E	3
Material:	Stainless Steel 316LN / 1.4429



www.inficon.com reachus@inficon.com

Due to our continuing program of product improvements, specifications are subject to change without notice.
RateWatcher is a trademark of INFICON. All other trademarks are the property of their respective owners.

(2018-08) © 2018 INFICON